

# FIREMAGIC®

## AURORA

### INFRARED BURNER KIT INSTRUCTIONS

Model # 3049 (A790, A660, & A530)

Model # 3051 (A540, & A430)

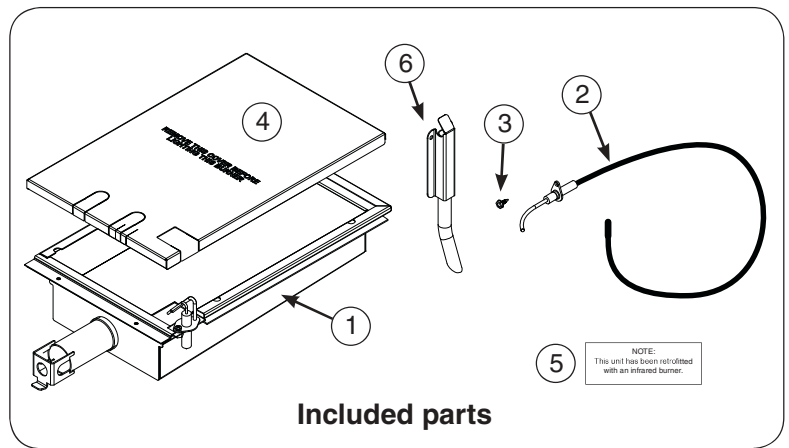

#### PARTS INCLUDED

1. Infrared burner
2. Ignitor wire
3. Self-tapping sheet-metal screw
4. Infrared cover
5. Conversion label
6. Lighting tube

#### TOOLS REQUIRED

- Phillips screwdriver
- 9/16 open-end wrench
- 1/4 nut driver or socket wrench

Table 1-1	Infrared Orifice Chart	
	Models A430, A540	Models A530, A660, A790
Natural	3001-49	3001-45
Propane (L.P.)	3001-56	3001-55

## INSTALLATION

### REMOVING THE LEFT MOST MAIN BURNER

1. **Be sure the grill is completely cool and the gas is completely shut off.** Open the oven lid and/or remove the warming rack and/or rotisserie rod as needed to access the cooking grids.
2. Remove the cooking grid and flavor grid from the left-most burner. Set the cooking grid aside. **The flavor grid will not be used with the infrared burner, and should be stored away.**
3. Remove the left most burner by first removing the burner clip (see Fig. 1-1) from under the back of the burner support. Then lift the back of the burner up out of the firebox by grasping the back and pulling upward. Continue to lift the back of the burner up while moving the whole burner back and out so that it pulls away from the forward fire wall opening and the orifice. Retain the clip with the burner so that they can be re-installed in the future if desired.
4. Remove the lighting tube by removing the two screws with the 1/4 nut driver (see Fig. 1-2). Retain the screws for attaching the new lighting tube.

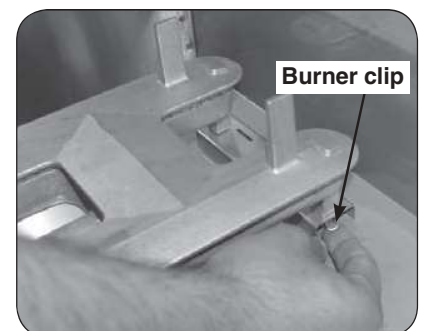

Fig. 1-1 Remove the grids and burner clip



Fig. 1-2 Remove old lighting tube

ROBERT H. PETERSON CO. • 14724 East Proctor Avenue • City of Industry, CA 91746

## INSTALLATION (cont.)

5. The grill is equipped with a heatshield kit for each main burner. This kit is only functional with the standard main burner, and must be removed for proper infrared burner operation. Use pliers to remove the diverter tube by bending in each side and pulling it outwards (see Fig. 2-1), then reach in and remove the silicone gasket (see Fig. 2-2).
6. Pull out and completely remove the drip tray from the grill.
7. With the burner valves in the **OFF** position, pull the valve knobs from their stems. Use a Phillips screwdriver to remove the control panel fastener screws on either side of the grill control panel (see Fig. 2-3). Release the control panel by lifting it slightly and remove it from the grill. Make sure to retain the screws and finish washers for re-attaching the control panel.

**Note:** To protect the wiring harness, carefully lift the control panel away from the frame and let it rest on the attached chain.

8. Lift the heat shield up and inward slightly to clear the diagonal slots hooked over the oven fire wall then pull away from the manifold (see Fig. 2-4).
9. Remove the existing ignitor wire by first sliding the rubber sleeve back off the ignitor, then pulling the wire to detach from the ignitor. Next remove the ignitor nut on the control panel side of the fire wall with a  $\frac{9}{16}$  open-end wrench (see Fig. 2-4) and remove the ignitor box from inside the oven. Remove the rubber sleeve from the wire and pull the wire through the heat shield and the insulating tube in the manifold fire wall. Disconnect the other end of the ignitor wire from the ignitor module (see Fig. 2-5).

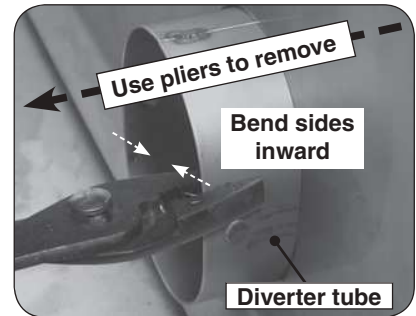

Fig. 2-1 Remove diverter tube

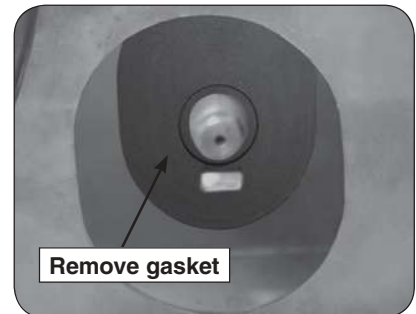

Fig. 2-2 Remove silicone gasket

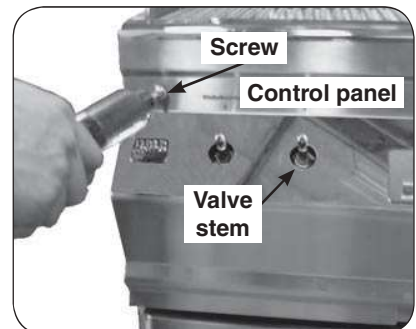

Fig. 2-3 Remove control panel

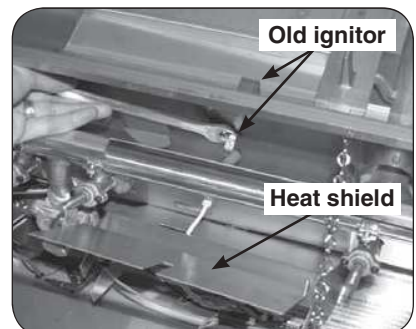

Fig. 2-4 Remove heat shield and old ignitor

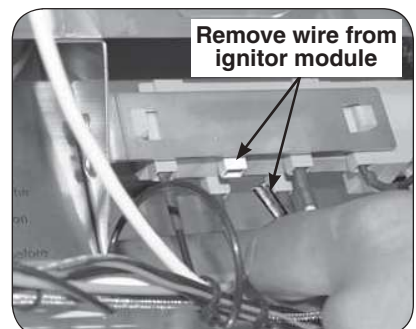

Fig. 2-5 Remove old ignitor wire

## INSTALLATION (cont.)

### INSTALLING THE NEW INFRARED BURNER

1. Locate the new ignitor wire with the insulator attached and thread the wire end through the hole in the oven fire wall left by the old ignitor, from the oven side as shown in Fig. 3-1. Continue to thread the wire end through the insulator tube in the manifold fire wall and through the slot in the heat shield, then route it toward the ignitor module on the right. (Hint: wrap around existing wire bundle.)
2. Attach the other end of the new ignitor wire (the insulated end) to any male connector on the back of the ignitor module (reference Fig. 2-5).

**Important:** Test all electrodes for spark before securing the control panel to the frame (see also the section on battery replacement in your owners manual).

**Note:** The wires can be plugged into any terminal.

3. Attach the insulated portion of the ignitor wire to the inside of the oven fire wall by placing the screw (included) through the bracket hole and into the hole in the fire wall (see Fig. 3-1 and Fig. 3-2).
4. Place the new infrared burner gas intake tube in the hole in the oven fire wall and over the orifice fitting, sliding it forward from behind the control panel frame, so the orifice is centered inside the burner gas tube. Set it gently onto the rear burner support, making sure the tabs on the back burner bottom each fit through their respective slots in the rear burner support. This is critical to the safe function of the grill. (See Fig. 3-3 and Fig. 3-4.)

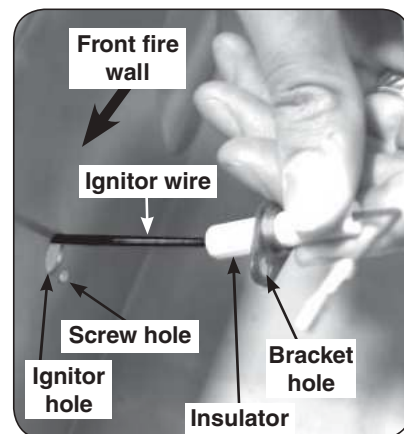

Fig. 3-1 Screw the new wire to the fire wall

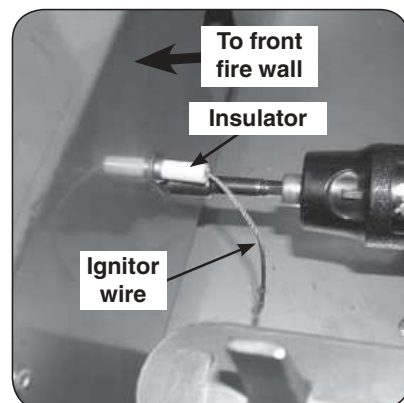

Fig. 3-2 Screw the new wire to the fire wall

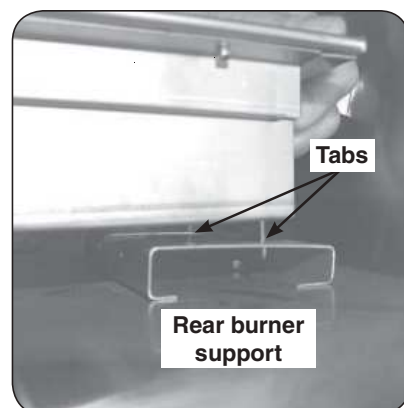

Fig. 3-3 Sliding tabs into support

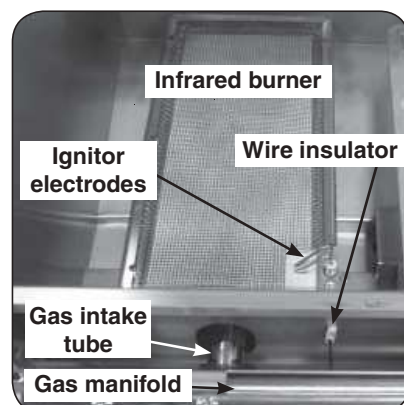

Fig. 3-4 Infrared burner installed

## INSTALLATION (cont.)

5. Connect the non-insulated metal end of the ignitor wire to the bottom of the ignitor electrode assembly at the forward right of the infrared burner (see Fig. 4-1).
6. Attach the new lighting tube (Fig.4-2) in place of the old one securing it with the old screws.
7. Apply the conversion label supplied with this kit to the inside of the fire wall behind the control panel so that it does not obscure any other labels (Fig. 4-3).
8. Reposition the heat shield by hooking the diagonal slots back over the sheet metal of the manifold fire wall.
9. Replace the control panel on the frame so the front lip of the control panel hangs from the forward lip of the frame. Re-secure the control panel with the fastener screws.
10. Replace the control knobs.
11. Replace the drip tray.
12. Replace the cooking grid. (DO NOT place the flavor grid on the infrared burner. It is not designed for use on an infrared burner, and should be stored away.)

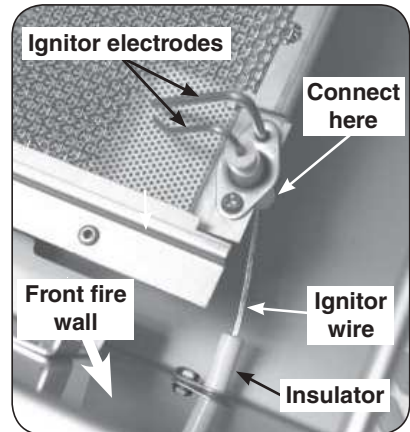

Fig. 4-1 Connect wire to electrode assy.



Fig. 4-2 Install new lighting tube



Fig. 4-3 Apply the conversion label

## OPTIONAL INFRARED BURNER OPERATION

The infrared (IR) searing burner (optional) cooks with a powerful radiant heat.

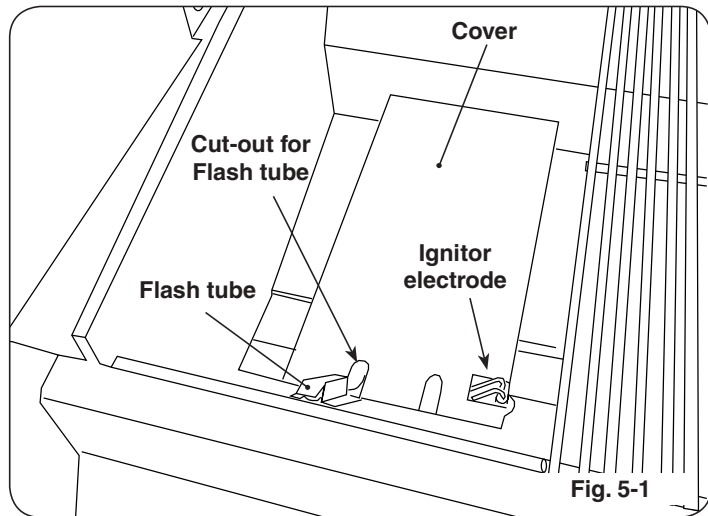

Fig. 5-1

Light the infrared burner following the LIGHTING INSTRUCTIONS in this manual or printed on the drip tray. Follow these guidelines when operating the Infrared burner:

- **DO NOT place food on the cooking grid until the IR burner glows orange (Fig. 5-3).** Drippings are heated and evaporate instead of sticking to and impairing burner function.
- **For cleaning purposes; always leave your burner on (after cooking) for an additional 5 minutes, to allow for a burnoff period. This is important to keep your burner clean and operating properly. As the burner is self cleaning (at full temperature); avoid the use of cleaners or abrasives.**
- When not in use, **always** cover the infrared burner with the stainless-steel cover. This protects the burner from drippings (from other cooking), airborne particles, and foreign objects (Fig. 5-2).
- Do not strike or scratch the burner ceramic as it may chip, crack, or break (Fig. 5-2).

**Note:** Digital thermometer does not give accurate readings for infrared burners.

**Important:** When grilling with the infrared burner, always place a cooking grid above it. The cooking grid must be removed for rotisserie cooking.

**CAUTION:** Never attempt to operate the IR burner with the protective cover in place.

### WARNING

Only handle the infrared burner cover when the grill is cold or with a well-insulated long-handled tool or heat resistant gloves.

### SIDE VIEW (with cover on)

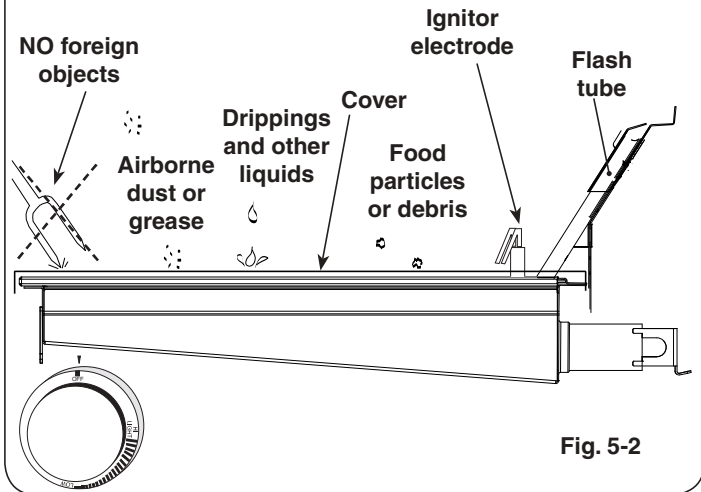

Fig. 5-2

Burner ceramic must be protected with cover when burner is not in use.

### SIDE VIEW (burner on HI LIGHT and glowing orange)

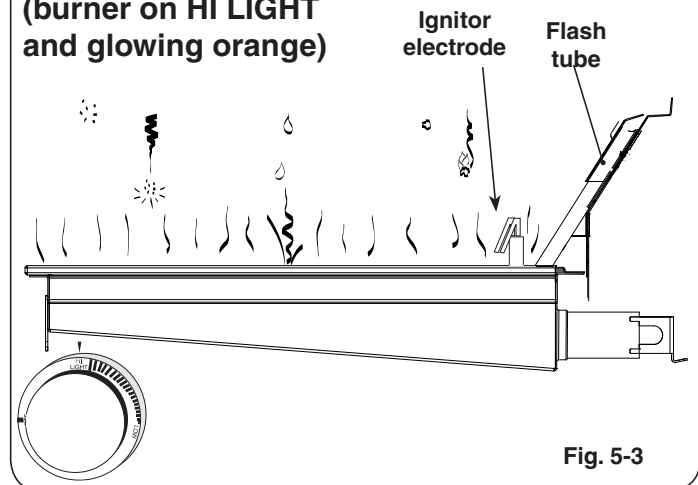

Fig. 5-3

Drips and particles evaporate before hitting infrared burner when cooking at the maximum setting.

**Note:** Flavor grids are not to be used with infrared burners.

**INFRARED BURNER NOTES PAGE**

Please use this page to record any information about your infrared burner that you may want to have at hand.