

# Fire Magic<sup>®</sup> CUSTOM I CLASSIC SERIES OUTDOOR GAS BARBECUE 52,000 BTU

*The Ultimate Barbecue*



**NOTICE TO INSTALLER:**  
These instructions must be left with the consumer

**NOTICE TO CONSUMER:**  
Please retain for future reference

Front to Back Depth 19-3/4", Width 26-1/4" Height 12", Open Front

## INSTALLATION AND OPERATING INSTRUCTIONS

**IMPORTANT: READ THESE INSTRUCTIONS CAREFULLY BEFORE STARTING INSTALLATION**

### FOR YOUR SAFETY IF YOU SMELL GAS:

1. Shut off the gas to the appliance.
2. Extinguish any open flame.
3. Open lid if equipped with an oven.
4. If odor continues, immediately call your gas supplier or fire department.

This appliance and its individual shutoff valves must be disconnected from the gas supply piping system when testing the system at pressures in excess of ½ psig.

This appliance must be isolated from the gas supply piping system by closing its individual manual shutoff valves during any pressure testing of the gas supply system at pressures up to and including ½ psig.

### FOR YOUR SAFETY

1. Do not store or use gasoline or other flammable vapors and liquids in the vicinity of this or any other appliance.
2. A propane cylinder not connected for use shall not be stored in the vicinity of this or any other appliance.

**WARNING:** Improper installation, adjustment, alteration, service or maintenance can cause injury or property damage. Refer to this manual. For assistance or additional information consult qualified, professional installer, service agency or the gas supplier.

**CODE AND SUPPLY REQUIREMENTS:** This barbecue must be installed in accordance with local codes and ordinances, or in the absence of local codes, with the latest National Fuel Gas Code, ANSI Z223.1. IN CANADA: The barbecue must include the Canadian Certification mark and bilingual marking with bilingual instructions to comply with the Canadian Interprovincial Gas Advisory Council (IGAC) requirements.

### CONTENTS

<i>Parts List (Exploded view)</i>	<i>Pg. 2</i>
<i>Planning for Installation</i>	<i>Pg. 3</i>
<i>Installing the Barbecue</i>	<i>Pg. 4-5</i>
<i>Adjusting the Barbecue</i>	<i>Pg. 5</i>
<i>Safety and Maintenance</i>	<i>Pg. 6</i>
<i>Use and Care</i>	<i>Pg. 6-7</i>
<i>Lighting Instructions</i>	<i>Pg. 8</i>

This manual may not be copied, photocopied, reproduced, translated, or published in any electronic or machine-readable form in whole or in part without prior written approval of Robert H. Peterson Co.

We reserve the right to amend product specifications without prior notice.

Robert H. Peterson Co. • 14724 East Proctor Ave., • City of Industry, CA 91746

# FIRE MAGIC CUSTOM I CLASSIC SERIES GAS BARBECUE PARTS LIST

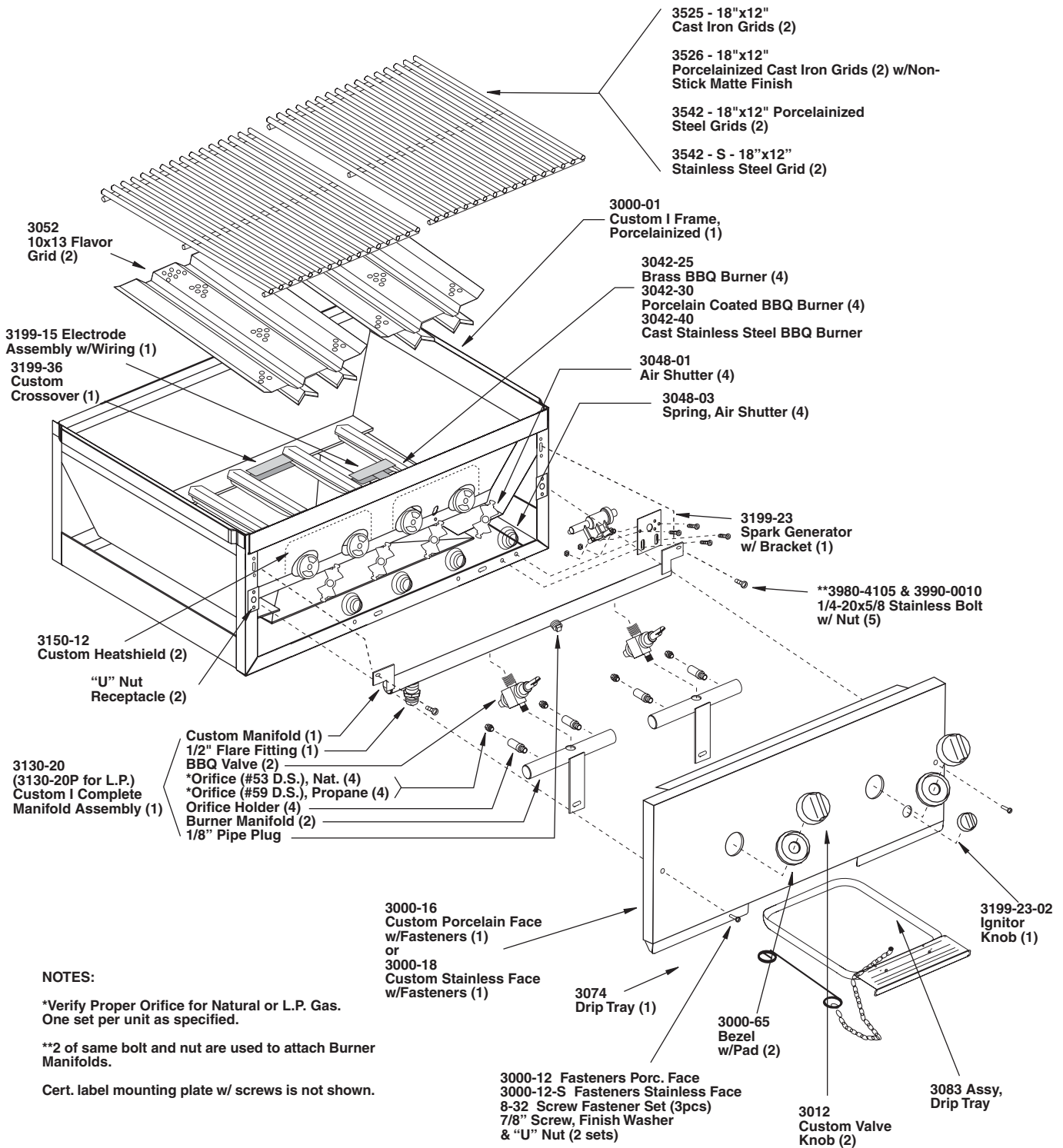

**NOTES:**

\*Verify Proper Orifice for Natural or L.P. Gas. One set per unit as specified.

\*\*2 of same bolt and nut are used to attach Burner Manifolds.

Cert. label mounting plate w/ screws is not shown.

**INSTRUCTIONS FOR  
FIRE MAGIC BARBECUE  
MODELS NO. 3130S thru 3131S**

**TOOLS REQUIRED FOR INSTALLATION**

- #2 (medium) phillips screwdriver
- Two medium size adjustable wrenches or pliers
- \*3/8" wrench or 3/8" socket screwdriver
- Pipe joint compound resistant to all gasses

\*Note: 3/8" socket if orifice change is required.

## PLANNING FOR INSTALLATION OF YOUR CUSTOM I CLASSIC SERIES BARBECUE

### WHERE TO INSTALL YOUR GAS BARBECUE

Fire Magic gas barbecues are designed for outdoor use only.

**WARNING:** Built-in models must be installed in masonry or other type of fireproof enclosure. The unit is not insulated and therefore must be installed with 18" of side and back clearance from unprotected combustible materials such as wood, plastic or stucco with wood framing.

With our insulating liner (part #3130-50) you can safely install your Fire Magic barbecue in wood cabinetry or other combustible enclosure.

For easy installation of your Fire Magic barbecue a masonry installation hanger (part #3130-70 for black finish & 3130-80 for stainless steel) is available. It eliminates the requirement for any type of support structure under the barbecue. This hanger can not be used in conjunction with the insulating liner above.

**Do not install this unit under unprotected flammable surfaces. Do not install or use this appliance inside a building, garage, or any other enclosed area including recreational vehicles or boats.**

This is a slide-in type unit designed to fit into open-front enclosures. The front panel (face) of the unit is removable for gas hookup, servicing and burner adjustment. The face must therefore be removable after you install the unit.

**INSTALLER NOTE:** This unit should be installed so that it can be removed at a later date if factory service is required. Any protrusion into the barbecue enclosure may obstruct the frame and prevent the unit from sliding into place (see "Gas Supply Plumbing Requirements", on page 4).

### INSURING PROPER COMBUSTION AIR AND COOLING AIR FLOW

You must maintain proper air flow for your Fire Magic barbecue to perform as it was designed (Figure 1). If airflow is blocked in any way, overheating and poor combustion will result. Make sure not to block the 1" front air inlet along the bottom of the barbecue face or the air vent openings along the outside-left and right edges of the frame. note: The 1" front air space also allows convenient access to the drip tray.

### VENTILATION OF ENCLOSURES

When using propane gas, take **EXTREME CAUTION** to ensure ample ventilation of gas vapor. Propane gas vapor is invisible and heavier than air. A **DANGEROUS EXPLOSION** could occur, resulting in **SERIOUS INJURY OR LOSS OF LIFE**, if propane gas is allowed to accumulate and is then ignited.

**Only one propane gas cylinder may be located in an enclosure.** Extra or spare cylinders must be stored outdoors out of the reach of children and outside of any building, garage or other enclosed area. **READ AND FOLLOW ALL WARNINGS PROVIDED WITH**

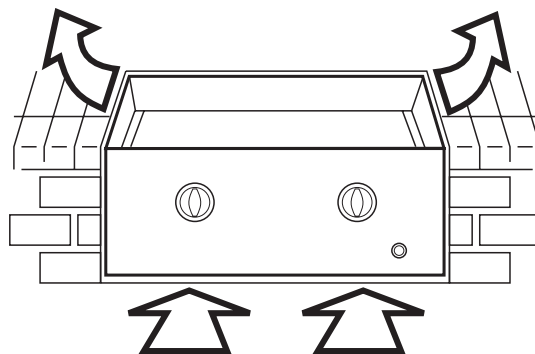

Figure 1 - Ventilation Diagram

**PROPANE GAS CYLINDERS. Never locate a cylinder under or near the barbecue** unless sufficient ventilation and shielding is provided to prevent any heating of the cylinder, regulator and rubber hose.

### Propane Cylinder Enclosures

To prevent invisible combustible gas from accumulating in the cylinder enclosure, you must provide adequate ventilation. This is accomplished by **EITHER** one side of the gas cylinder enclosure left completely open to the outside **OR** by providing four (4) ventilation openings. Two openings are to be at the cylinder valve level (Approx. 16" above the floor) and at opposite walls of the enclosure. Two more openings must be at the floor level at opposite sides of the enclosure. The floor level openings must start at the floor and shall extend no higher than 5" above the floor. Each opening must have a minimum of 10 square inches (64.5 cm<sup>2</sup>) of free area. To achieve the proper ventilation, you may drill a series of holes, omit the grout from masonry joints or replace a brick with a hardware cloth screen. If the floor in the cabinet is raised and the space beneath the cabinet is open to the outside, the lower ventilation openings may be in the floor.

**FOR YOUR SAFETY,** you must provide these openings for drainage, replacement air and cross ventilation of any storage area exposed to possible leakage from gas connections, the barbecue or propane gas cylinder.

**IMPORTANT:** Read additional requirements for safe use of propane gas and gas cylinders appears below.

### HOUSEHOLD PROPANE GAS SERVICE

Consult your gas supplier for ventilation and regulator requirements when connecting to a **HOUSEHOLD** propane supply.

**NOTE:** Only Fire Magic barbecue models with the suffix -PA- in the model number are approved by C.S.A. for self contained propane cylinders. Supplemental instructions are supplied with each self contained unit.

### ELECTRICAL OUTLETS

Electrical outlets in the vicinity of the barbecue, which might be used for rotisserie motors or other appliances, must be properly grounded.

**Installer and User Note:** Keep electrical supply cords away from all heated surfaces.

## EXHAUST REMOVAL

If installed under a patio roof, the grill area should be fully covered by a non-combustible chimney and exhaust hood. An exhaust fan with a rating of up to 1000 CFM may be necessary to efficiently remove smoke and other cooking by-products from the covered area. Installation in fully-enclosed patio areas is not recommended.

## GAS SUPPLY PLUMBING REQUIREMENTS

Rigid 1/2" or 3/4" black steel pipe, or local code approved pipe for temperatures up to 800°F (427°C), is required to conduct the gas supply into the enclosure opening for connection to the unit.

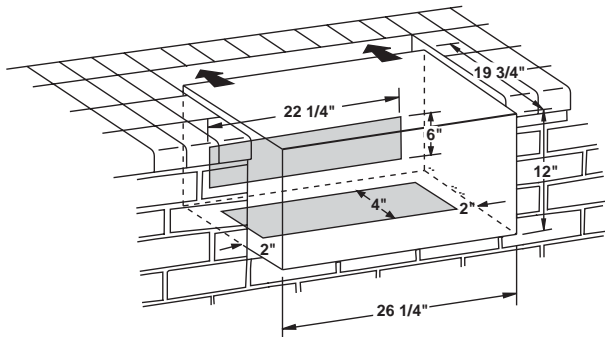

Figure 2 - Gas Stub Diagram

Apply only joint compounds that are resistant to all gasses on all male pipe fittings. Make sure to tighten every joint securely. Do not use pipe joint compound to connect flare fittings.

The gas supply pipe should enter from the rear wall of the enclosure behind the barbecue unit, at least 2" from either side, and between 2" and 8" above the floor as illustrated by the shaded area in Figure 2.

If it is not possible to stub the gas line in from the back of the enclosure, the connection may be made through the floor at the rear of the enclosure. Install the gas line stub at least 2" away from the side and back walls, but within 6" of the back wall as illustrated by the shaded area in Figure 2.

**SAFETY NOTE:** An external valve (with a removable key) in the gas line is necessary for safety when your barbecue is not in use. It also provides for convenient maintenance and repair.

## GAS SUPPLY AND MANIFOLD PRESSURES:

For natural gas - normal 7" water column, minimum 3 1/2", maximum 10-1/2". For propane gas - normal 11" water column, minimum 8", maximum 13".

## INSTALLING YOUR FIRE MAGIC CUSTOM I CLASSIC SERIES BARBECUE

Perform the following checks before installing your barbecue:

### 1. CHECK FUEL ORIFICES FOR PROPER SIZE

Your Custom I Classic barbecue is equipped with fuel orifices for natural gas, unless otherwise indicated. To use with propane gas, you must install smaller orifices to avoid hazardous overheating. The proper orifice size for natural gas is #53 (drill size). The proper orifice size for propane gas is #59 (drill size).

### 2. IF YOU ARE NOT SURE YOU HAVE THE CORRECT BARBECUE BURNER ORIFICE SIZE:

a. Remove the cooking grids and flavor grids from your barbecue.

b. If the gas supply has been connected, make sure the burner valves are in the "OFF" position. Then pull the valve knobs from their stems. Use a phillips screwdriver to turn the face fastener screws counter clockwise to release the face and remove it from the barbecue. Make sure to retain the screws and finish washers until you are ready to reattach the face.

**NOTE:** Carefully lift the face away from the frame. The spark generator for the ignition system is attached to the inside of the face panel. The ignitor knob need not be detached, but the wires must be unplugged from the generator before the face is removed.

c. Lift off and remove one of the three galvanized steel heatshields which are resting over the necks of each pair of burners.

d. Check the orifice size by lifting a burner up off of the stainless steel screw, or peg, at the back side of the unit and pulling it away from the orifice. The drill size is stamped on the face of each orifice. Be sure not to lose the air shutter or air shutter spring which may become detached when the burner is removed.

e. Change all four orifices if necessary, following instructions provided with your replacement orifices (furnished with all Fire Magic gas barbecues).

f. After checking orifice drill size, install the air shutter spring and the air shutter over the orifice holder fitting, between the burner and the pipe manifold, in the order and position shown in Figure 3.

g. Carefully place the burners back on the screws or pegs so that the brass orifice and orifice holder fittings project deeply into the burners.

h. Replace the galvanized heatshields.

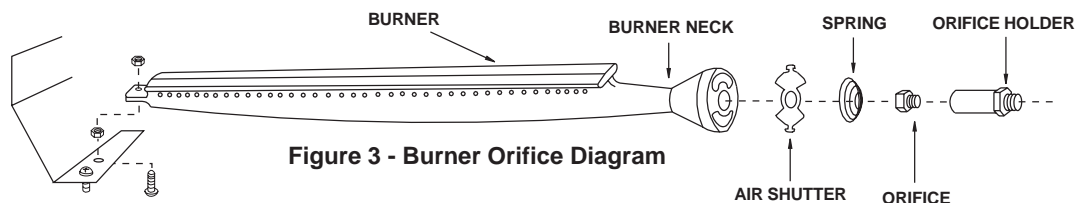

Figure 3 - Burner Orifice Diagram



### 3. CONNECT THE GAS SUPPLY TO BARBECUE

a. You will need a CSA approved stainless steel flex connector to bring the gas supply from the gas line stub to the valve manifold. A 1/2" x 36" or 48" flex connector with 1/2" flare to 1/2" pipe adapter on one end, and a 1/2" flare female fitting on the other end is suitable for most installations. **CAUTION: Use only stainless steel flex connectors that are C.S.A. listed.**

**WARNING: A rubber or plastic connector will rupture or leak, resulting in an explosion or serious injury if used inside the barbecue enclosure.**

b. Make sure that your gas supply is turned off! Then connect the 1/2" pipe adapter fitting supplied with the stainless steel flex connector to the gas supply stub. Use pipe joint compound that is resistant to all gasses on the male pipe fitting and tighten securely. **Do not use pipe joint compound to connect the flare fittings.**

c. Slide your barbecue into place, making sure not to pinch or kink the gas connector.

d. Bring the flex connector around the left-hand side of the barbecue. Use the locator angle brackets on the left lower-frame to position the flex connector. Continue the flex connector along the left side to the front of the unit and the valve manifold Inlet. Be careful not to block the 1" front vent opening as this will obstruct drip tray removal.

e. Connect the flex connector to the flare fitting on the manifold Inlet. Support the manifold inlet fitting with a wrench to avoid applying excessive torque to the manifold assembly while tightening this connection securely. Do not use pipe compound on flare fittings.

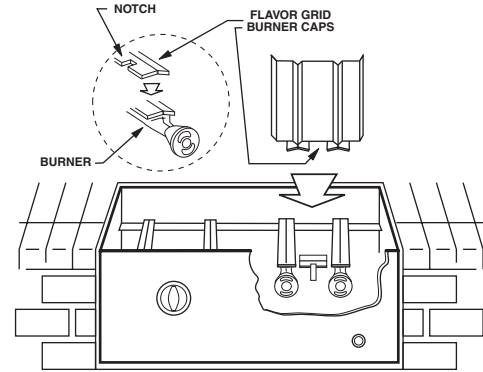

Figure 4 - Flavor Grid Diagram

f. Make sure the barbecue burner valves are in the "OFF" position. Turn the gas supply on. Then carefully check all gas connections for leaks with a brush and soapy water before lighting. **NEVER USE A MATCH OR OPEN FLAME TO TEST FOR LEAKS.**

g. Refer to the "Air Shutter Adjustment" instructions below before replacing barbecue face and knobs.

### 4. INSTALL THE FLAVOR GRIDS

a. Place the flavor grid burner caps directly on the burners. Make sure the notched end of the burner cap rests over the ignitor box (figure 4). Center the grids over the burners with the open side up. This allows heat from the burners to be evenly distributed throughout the cooking area. Flavor grids heat and cool quickly, making your Fire Magic barbecue very responsive to the changes you specify in grill temperature.

The flavor grids are made of stainless steel. They are rust resistant and may be cleaned with standard oven cleaners.

## ADJUSTING YOUR BARBECUE

**IMPORTANT: This appliance will not light and will not heat evenly or cook properly unless the air shutters are adjusted following installation (reference "Air Shutter Adjustment", below).**

Burner air shutters are easily accessed by removing the front panel (face). The air shutters are located at the front of the burners behind the face and in front of the heat shields (see page 2). Close the air shutters with the tabs pointing up and down (Figure 5B). Light your barbecue in accordance with the manual lighting instructions found on page 8 and burn for 5 minutes with both valves on high and the oven open.

### AIR SHUTTER ADJUSTMENT

After burning for 5 minutes, open the air shutters until the flames lift off, or appear not to be touching the burners. Then begin closing the air shutters until the flames appear to burn while touching the burner ports (Figure 5B). You may then see short yellow tips on the flames. If flames are a lazy yellow, open the air shutters until the flame is blue with yellow tipping.

**NOTE:** Barbecues in some installations achieve a better air/gas mixture and **will ignite more quickly** if the valve is first turned beyond high to medium or low for lighting.

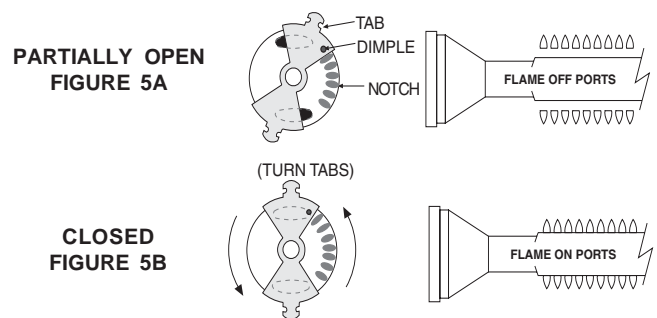

Figure 5A & 5B - Air Shutter Adjustment Diagram

### ADJUSTING THE FLAME HEIGHT

The large knobs on the face of the barbecue control the valves and adjust flame height. The first position is "high," the second "medium" and the final "low." Flame height can also be set anywhere between the high, medium, and low settings for all cooking requirements and tastes.

Height of the flame with the **valve in low position** may be regulated by means of a small adjusting screw in the center of the valve stem. This screw is accessible by removing the plastic valve knob which pulls straight off the end of the valve stem.

## SAFETY INFORMATION

Every time you use your barbecue, make sure that:

1. The area around the barbecue is clear of flammable substances such as gasoline, yard debris, wood, etc.
2. There is no blockage of the air flow through the vent space located below the face of the unit.
3. When using propane gas:
  - a. The special ventilation openings in the enclosure are kept free and clear of debris.
  - b. If connected to a propane cylinder, the rubber hose attached to the regulator is carefully inspected before each use.
  - c. The propane cylinder, regulator and rubber hose are installed in a location not subject to heating above 125° F (51° C).
4. The burner flames burn evenly along both sides of each burner with a steady flame (mostly blue with yellow tipping). See 'Air Shutter Adjustment'. If burner flames are not normal, check the orifice and burner for insects or insect nests (see page 4 - Checking Fuel Orifices).
5. The drip collector holes are clear and unobstructed. Excessive grease deposits can result in a grease fire.
6. The in-line gas valve or gas cylinder valve is always shut off when the barbecue is not in use.

### DRIP COLLECTION SYSTEM

The drip collector in this Fire Magic barbecue is part of the unit's main frame, and is located below the burners. The drip collector has three holes which allow excess drippings to fall through during cooking while separating the firebox from the drip tray.

The drip collector allows you to brush or scrape residue from the barbecue inner liner into the drip tray. Regular cleaning of your barbecue interior with oven cleaner or **Fire Magic Foaming Barbecue and Grill Cleaner**, will prevent grease fires.

### PREPARING THE BARBECUE FOR COOKING

To extend the life of your Fire Magic barbecue, follow these steps prior to cooking:

1. Begin by heating the unit at a normal cooking temperature for several minutes.
2. Then open the control valves to the "High" setting to burn off residue remaining from prior use.
3. When the barbecue has heated sufficiently, set heat to the desired cooking level.
4. When using a smoke oven, closing the cover during the preheat period will accelerate the preparation process. Do not operate unattended at high flame as cooking temperatures will quickly be exceeded.

**WARNING: Never cover the entire cooking or grill surface with griddles or pans. Overheating will occur and burners will not perform properly when combustion heat is trapped below the cooking surface.**

**CAUTION: Never spray water on a hot Barbecue as this may damage the unit.**

## USE AND CARE OF YOUR BARBECUE

### FLAVOR FROM WOOD CHIPS OR CHARCOAL

Convenient **Fire Magic Gourmet Grilling Chips** are sold in several different popular wood types. These chips are pre-moistened and sealed in cans which can be opened, by lifting the tabbed lid, before placing the entire can on the flavor grid to add natural wood smoke flavor to the food you grill. There is no mess to clean up. Just discard the can of ashes after there is no longer any wood smoke aroma.

You may also add wood chips, wood chunks or the natural wood charcoal of your choice to the flavor grid. We recommend placing wood outside the direct cooking zone or wrapping it in perforated aluminum foil. Soaking wood before use will slow burning and increase smoke flavor. Wood and charcoal ash will remain in the flavor grid after use. The grid can be easily removed and cleaned when the unit has fully cooled.

### CARE OF STAINLESS STEEL COMPONENTS

If your barbecue has a stainless steel oven and front panel, the following care instructions will keep your unit looking and working like new. Stainless steel components are constructed of the finest prime grade type 304 stainless steel. Meticulous attention has been given to maintain the attractive finish throughout the manufacturing process. Like the stainless steel used in commercial kitchens, your barbecue requires regular cleaning and occasional buffing to maintain its bright, clean appearance.

Deposits of dirt and grease can be removed easily with **Fire Magic Foaming Barbecue and Grill Cleaner**. Deposits should be removed before they are allowed to bake onto the finish. To remove more stubborn deposits, use a scouring pad recommended for stainless steel. Be sure to always rub in the direction of the polishing lines (Figure 6). Oven cleaner may be used, according to manufacture's instructions, to remove cooked-on food deposits. Special cleaning agents and

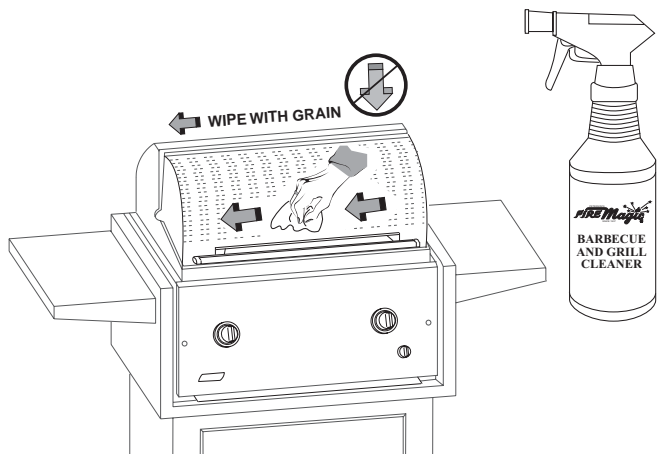

Figure 6 - Always rub with the grain

polishing pads recommended for stainless steel are available at your local barbecue dealer, hardware store or supermarket.

**CAUTION:** Never use ordinary steel wool or steel brushes on stainless steel. Tiny particles left behind may rust and stain the finish. Abrasive pads recommended for restoring the grain in stainless steel will, over a period of time, scratch or dull the surface of glass or porcelain-coated products.

### BURNER MAINTENANCE

Fire Magic burners are constructed of heavy-duty cast stainless steel (cast brass and porcelainized cast iron burners are also available) and will withstand many years of outdoor use, if ordinary precautions are taken. Once or twice a year inspect the burners and determine if dirt or debris is building up excessively. Burners can be removed and scraped to remove debris from ports. Replace burners immediately if they show any signs of weak or thin walls. Refer to the bottom of page 4, Figure 3 for installing burners.

### STAINLESS STEEL COOKING GRIDS

Fire Magic stainless steel cooking grids are finished with a special matte (satin) finish. This special matte-finish provides a more stick-resistant cooking surface that makes outdoor barbecuing easy and enjoyable. And, because it is made of type 304 stainless steel, you'll enjoy a lifetime of outdoor cooking. For best cooking performance, follow the simple steps of 'Care and Maintenance' after every use. Fire Magic stainless steel cooking grids are warranted for as long as you own them.

### CARE AND MAINTENANCE (Stainless Steel Grids)

To maintain your stainless steel cooking grids we recommend lightly brushing the grids after use with a brass or stainless steel wire brush. Before use, brush again if necessary and spray a light coat of vegetable oil over the cooking surface. Discoloration or stubborn food particles can be removed with a heavy-duty abrasive or stainless steel scouring pad. Grills can also be washed in an automatic dishwasher or cleaned with strong cleaning solutions, including oven

cleansers. We do not recommend ordinary steel or wire brushes, which may leave tiny metal particles on the grids which cause discoloration, but not permanent damage.

### PORCELAIN COATED CAST IRON GRIDS

Fire Magic porcelain-finished cast-iron grids are coated with a special high-temperature porcelain in a matte (satin) finish. This special matte-finish porcelain coating provides a stick resistant cooking surface that makes outdoor barbecuing easy and enjoyable. And, because it resists corrosion, the finish also increases cooking grid durability to provide years of cooking enjoyment. For best cooking performance, the wide side of the grid bars should face up.

### CARE AND MAINTENANCE (Porcelain Coated)

A spray coat of vegetable oil and light brushing with a brass grid brush before and after use is all it takes to maintain cooking readiness and ensure long life.

### PROTECTING PARTS AND FINISH

A heavy duty cover will protect the finish on your Fire Magic smoke oven and preserve your barbecue investment. The water repellent material will shield your smoke oven from scratches, corrosion and oxidation. The specially developed Thermo-Magic material is flame retardant, allowing the cover to be placed on your barbecue immediately after it is turned off and before cooling.



## LIGHTING INSTRUCTIONS

Follow these instructions each time you light your Fire Magic barbecue.

### FOR AUTOMATIC LIGHTING:

1. Read these instructions before lighting.
2. Open the lid of the smoke oven.
3. Turn both barbecue gas valves to the "OFF" position.
4. Turn on the gas at the source outside of the barbecue enclosure.

**NOTE: DO NOT** turn on more than one valve at a time for either automatic or manual lighting. Adjacent barbecue burners will cross-ignite.

5. Push the right gas valve and turn to "HIGH" then immediately turn the light knob several times in the direction of the arrows.

**CAUTION:** If the burners do not light, IMMEDIATELY turn the valve to "OFF" and WAIT 5 MINUTES before repeating step 5. If the burners still do not light, refer to the instructions below for manual lighting.

**NOTE:** Barbecues in some installations achieve a better air/gas mixture and **will ignite more quickly** if the valve is first turned beyond high to medium or low for lighting.

### FOR MANUAL LIGHTING:

**CAUTION:** Always wait 5 minutes for gas to clear after any unsuccessful lighting attempt.

**Follow steps 1 through 4 above.**

5. Insert either a burning long-barrel butane lighter, a burning long-stem match or a burning match held by a wire extension holder through the cooking grids to the burners below the flavor grid.
6. While holding the match or lighter flame next to the burner, depress the appropriate valve knob and turn it counterclockwise to the "HIGH" position. Adjacent burners will cross-ignite.
7. If the burner does not light, IMMEDIATELY turn the valve to "OFF" and WAIT 5 MINUTES before repeating steps 2 through 4 of the manual lighting instructions.

**Replacement parts may be obtained from your nearest Fire Magic dealer. For assistance in locating a dealer, please contact our factory at the address listed below.**

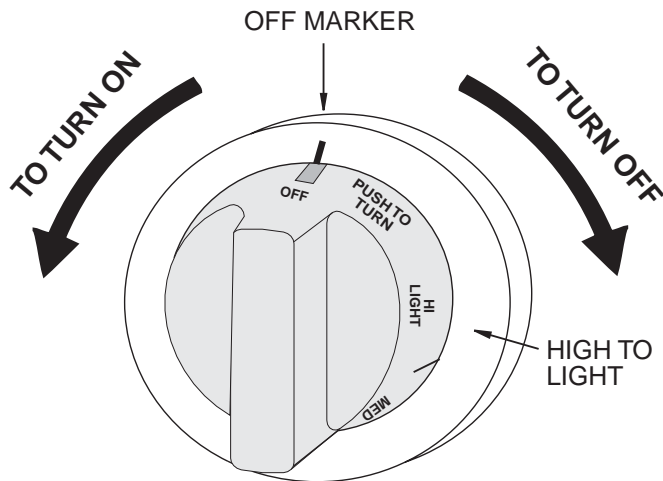

Figure 7 - Valve Control Knob



Figure 8 - Match Holder

**REMEMBER:** FOR SAFE MANUAL LIGHTING, PLACE A BURNING MATCH OR BUTANE LIGHTER BESIDE THE BURNER - THEN TURN ON THE GAS (Figure 9).

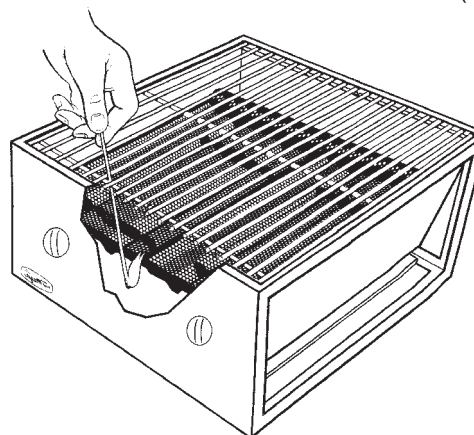

Figure 9 - Manual Lighting

### IF YOU SMELL GAS

1. Shut off gas to the appliance.
2. Extinguish any open flame.
3. Open lid if equipped with oven.
4. If the odor continues, immediately call your gas supplier or fire department.

## ROBERT H. PETERSON CO.

Quality Check \_\_\_\_\_

Date: \_\_\_\_\_

Orifice # (MAIN): \_\_\_\_\_

Orifice # (OTHER): \_\_\_\_\_

Leak Test: \_\_\_\_\_

Burn Test: \_\_\_\_\_

Gas Type: NAT / PROPANE

Model #: \_\_\_\_\_

Serial #: \_\_\_\_\_

Air Shutter: \_\_\_\_\_

Inspector: \_\_\_\_\_